

HH030L

Payload 30Kgf

Installation method		Application	
Floor	●	Spot welding	
Ceiling	●	Arc welding	
Wall surface	●	Handling	●
		Assembly	●
		Sealing	●
		Painting	

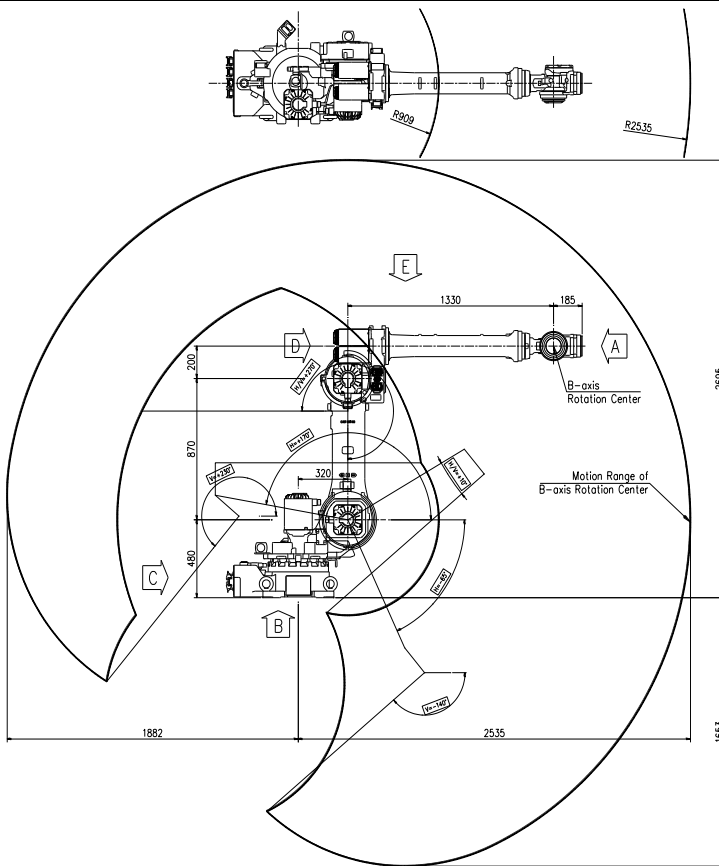

Item		Specification	
Robot model		HH030L	
Payload		30 Kg	
Structure		Articulated	
Degree of freedom		6 axes	
Max. working envelope	Arm	S Swivel	$\pm 3.141 \text{ rad } (\pm 180^\circ)$
		H Horizontal	$+2.967 \text{ rad } \sim -1.134 (+170^\circ \sim -65^\circ)$
		V Vertical	$+3.141 \text{ rad } \sim -1.396 (+180^\circ \sim -80^\circ)$
	Wrist	R2 Rotation 2	$\pm 6.283 \text{ rad } (\pm 360^\circ)$
		B Bending	$\pm 2.182 \text{ rad } (\pm 125^\circ)$
Max. working speed	Arm	S Swivel	$2.618 \text{ rad / s } (150^\circ / \text{s})$
		H Horizontal	$2.443 \text{ rad / s } (140^\circ / \text{s})$
		V Vertical	$2.618 \text{ rad / s } (150^\circ / \text{s})$
	Wrist	R2 Rotation 2	$4.363 \text{ rad / s } (250^\circ / \text{s})$
		B Bending	$4.363 \text{ rad / s } (250^\circ / \text{s})$
Wrist torque	R2 Rotation 2	$200 \text{ Nm } (20.4 \text{ Kgfm})$	
	B Bending	$200 \text{ Nm } (20.4 \text{ Kgfm})$	
	R1 Rotation 1	$100 \text{ Nm } (10.2 \text{ Kgfm})$	
Accuracy of position repeatability		$\pm 0.1 \text{ mm}$	
Ambient Temperature		$0 \sim 45^\circ \text{C } (273 \sim 318 \text{ K})$	
Robot's Weight		650 Kg	

View A: Detailed drawing of the wrist attachment part

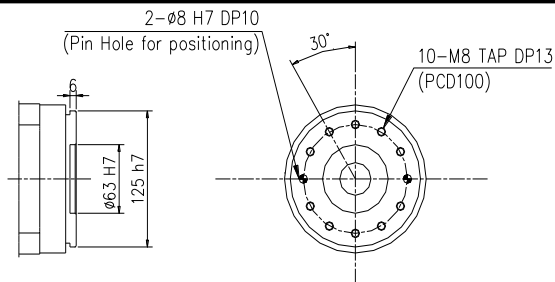

View B: Dimensional drawing for the floor installation of the body

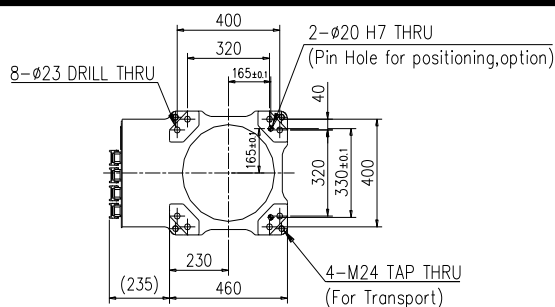

Wrist-axis torque line diagram

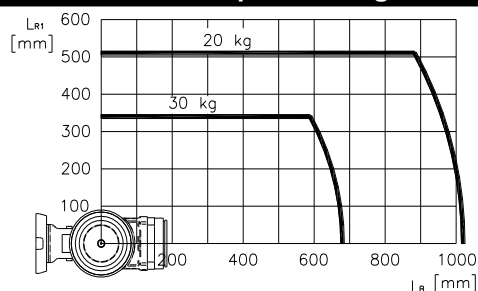

View C: Application cable connection part (Option)

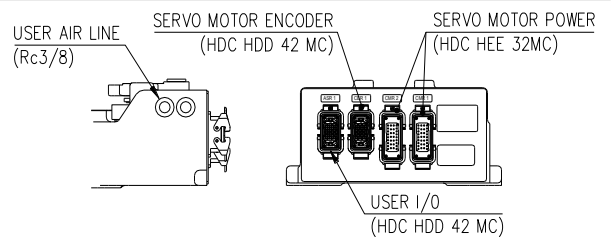

View D: Application cable connection part (Option)

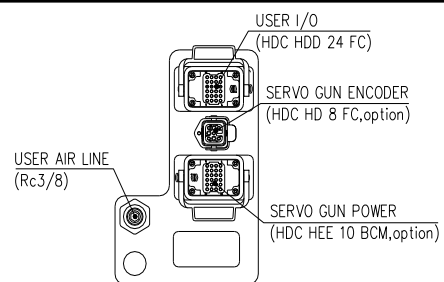

View E: Details of the application ancillary part attachment

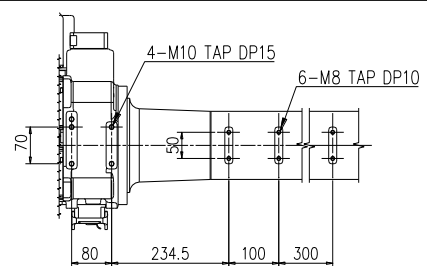

** For product improvement, some of the ratings, specifications, dimensions, etc. are subject to changes without notice.

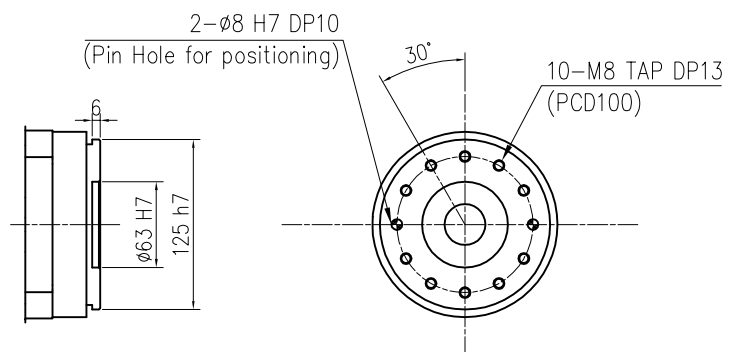

VIEW "A"
(SCALE : 4/1)

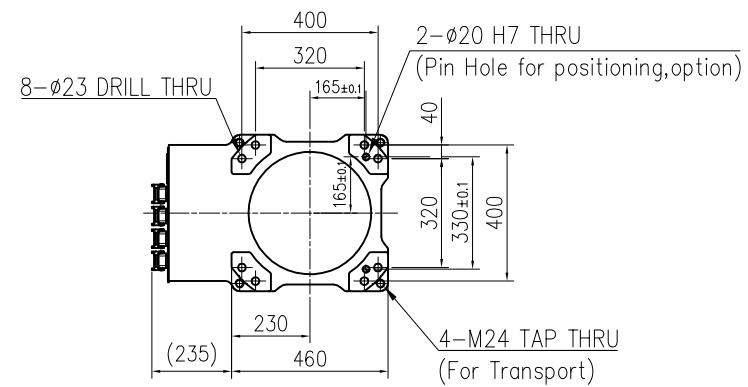
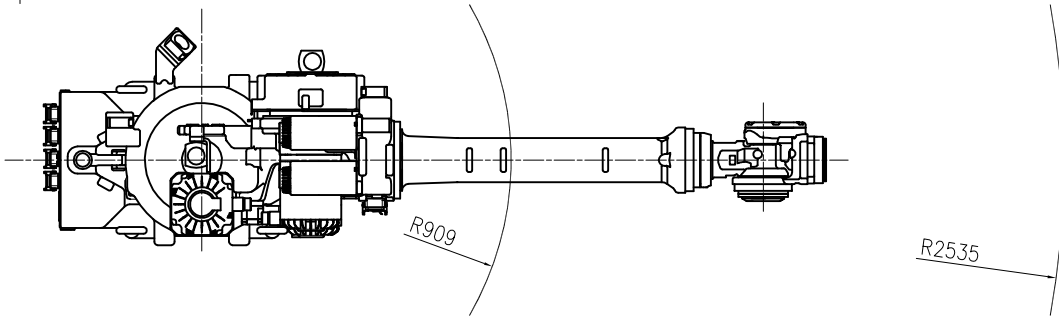

VIEW "B"
(SCALE : 1/1)

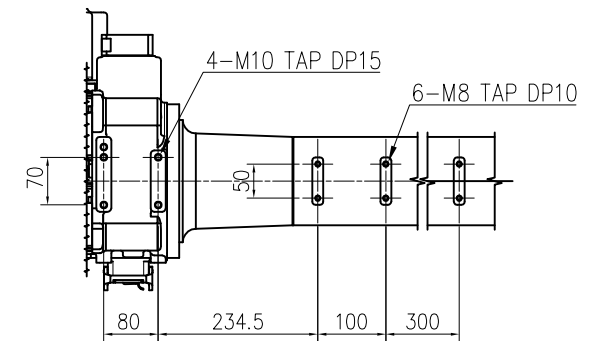

VIEW "E"
(SCALE : 2/1)

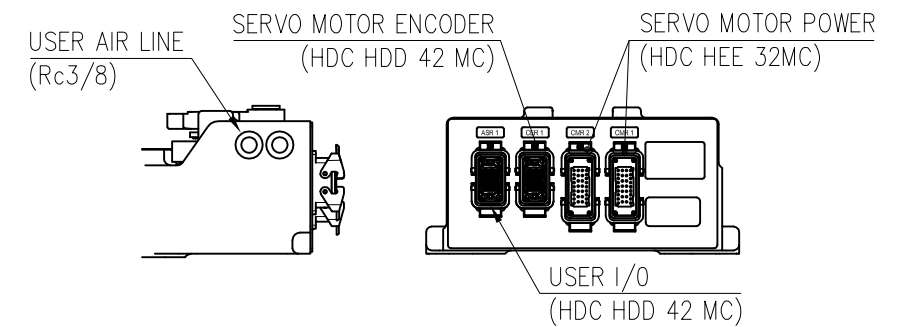
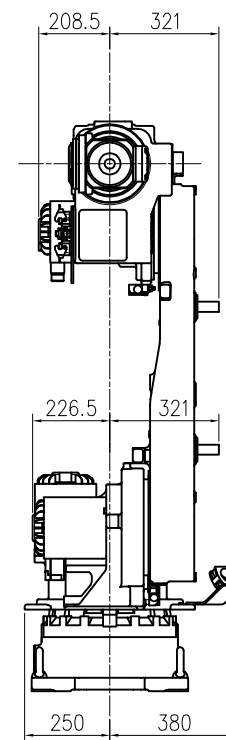
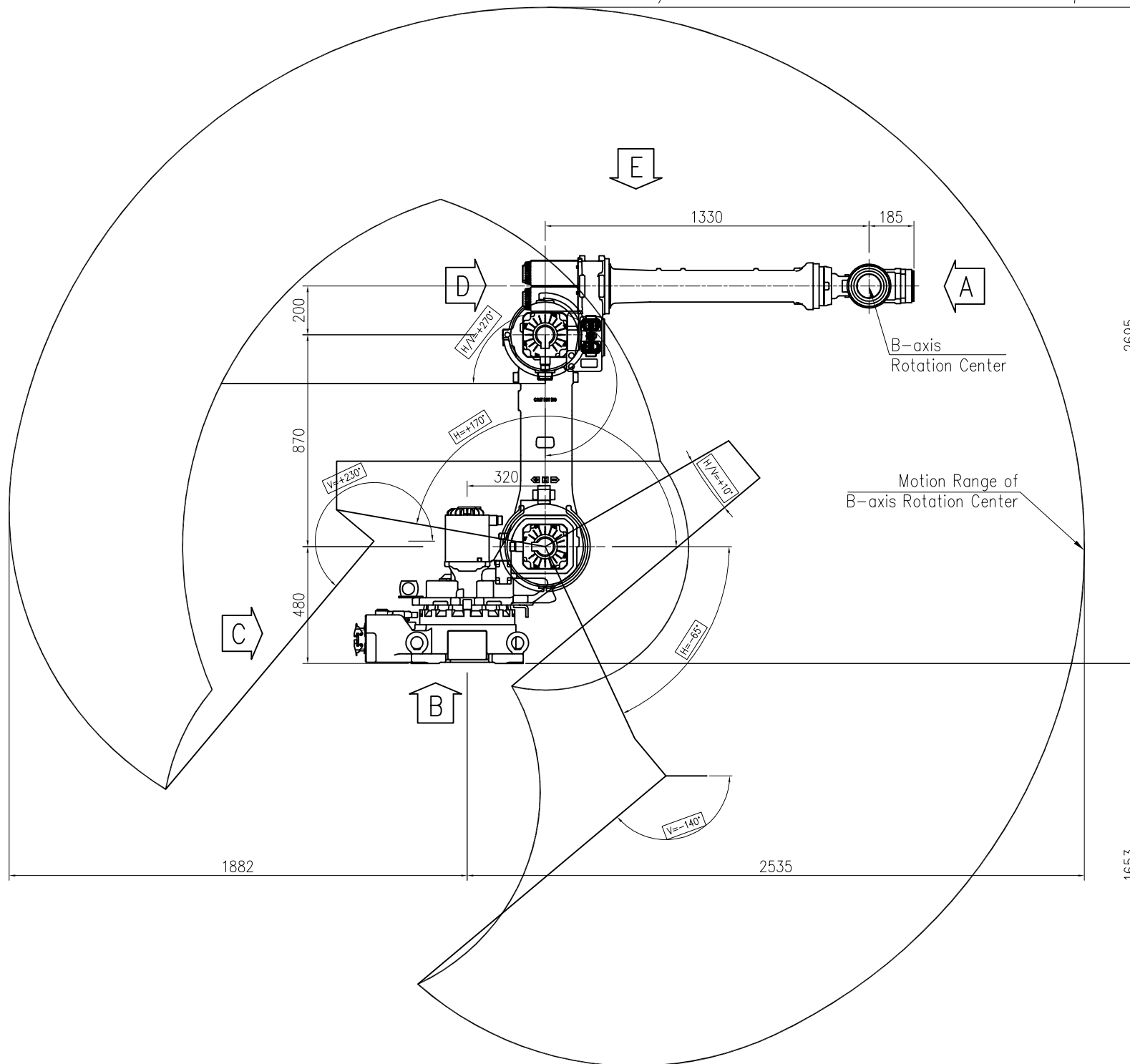

VIEW "C"
(SCALE 2/1)

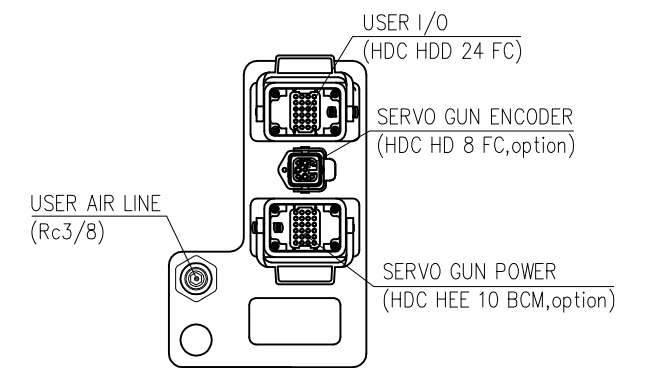

VIEW "D"
(SCALE : 4/1)

MODEL	HH030L	issue.0
DATE	2018.06.19	

TECHNICAL SPECIFICATION SUBJECT TO CHANGE WITHOUT NOTICE

